

Coolview HD-LED®

Examination Lights



HD
LED

High Definition
LED Lighting

Coolview HD-LED Examination Light

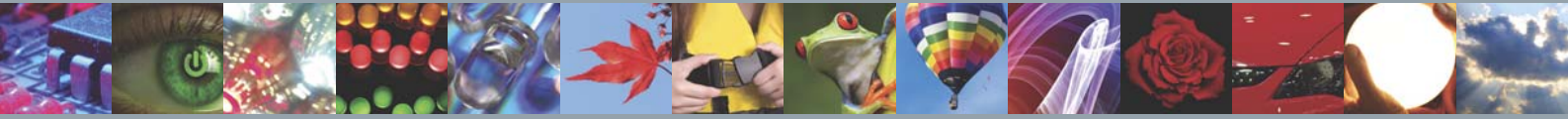

“HD-LED is a breakthrough technology that changes the fundamental parameters of lighting. Seven powerful LEDs provide the very best, high quality lighting for examination”



Full Spectrum Colour Rendition

The only examination light to provide near perfect colour rendition across the full visible spectrum. Natural white light picks out all the visible colours for your eyes so you can see clearly without eye strain.



Fat Beam Illumination

Coolview HD-LED provides a large illuminated field of 17cm at 0.5m. High intensity light is spread across the entire illuminated area for uniform vision.



Red Colour Rendition

The highest R_9 red colour rendition of any product provides the optimum visualisation of red tissue. The red colour rendition compensates for our natural weakness in distinguishing shades of red.

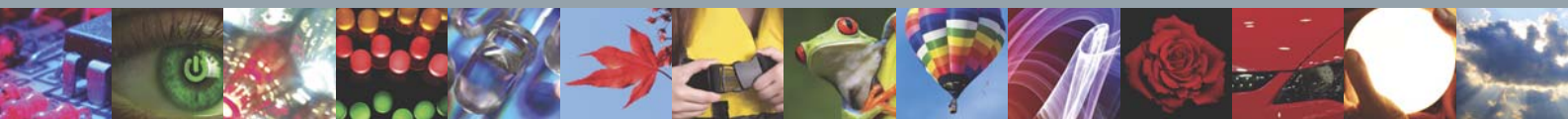

Quality, Safety and Reliability



HD-LED Lighting

- LED life: > 40,000 hours
- Light intensity: 50,000 @ 0.5m
- Colour Rendition Index: $R_a = 95$
- Colour Rendition: $R_9 = 95$ (visible red)

Colour Control Settings

- Adjusting the light colour enhances the physician's ability to recognise and distinguish tissue conditions. Different characteristics are easier to see under each colour setting.



Warm White
3500K

Ideal for different types of skin examinations



Neutral White
4100K

Ideal for general examinations



Cold White
4700K

Ideal for the recognition of blood vessels

5 Intensity Settings

- The light intensity can be altered through 5 easily selectable settings between 10%-100%, providing the most suitable intensity for any type of examination.

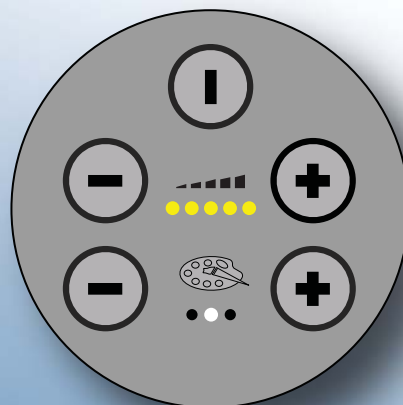

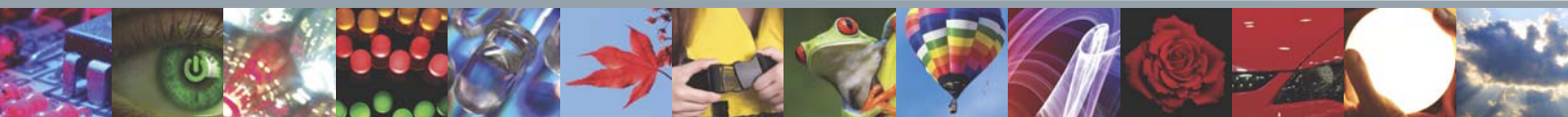

Positioning and Long Reach

- Innovative articulated arm system using directional load compensation (DLC) ensures the light is easy to move, easy to position and does not drift.
- Long reach arm extends to 1200mm to provide a large working envelope.
- Ceiling models have a full 360° rotation about the ceiling pole.



Cold Light

- Coolview HD-LED does not emit any infrared radiation, avoiding heat exposure during examinations.
- Ideal colour rendition for impeccable recognition of colour nuances, particular for skin and reddish tones.

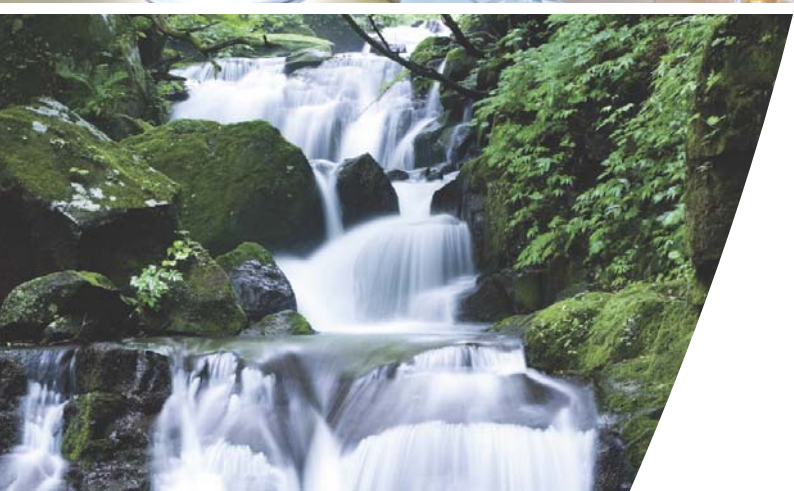

Environmentally Friendly

- Coolview HD-LED emits an intense bright light equivalent to a 50W halogen but only uses 20W.
- No Mercury, Lead, Cadmium, CFCs, PoPs, VOCs or Halogens.
- LED life is 40,000 hours, over 20 years of normal use, making Coolview HD-LED highly economical.

Technical Information

Coolview HD-LED

TECHNICAL DATA

ILLUMINANCE FIELD 0,5 M	Ø 17 cm
COLOUR TEMPERATURE	approx. 3500 K / 4100 K / 4700 K
LUMINAIRE BODY	polycarbonate (PC)
POWER CONSUMPTION	approx. 25 W
BALANCE OF ARTICULATION JOINTS	directional load compensation (DLC)
CLASS OF PROTECTION	I
SAFETY STANDARDS	EN 60601-1, EN 60601-2-41
SPECIAL FEATURES	3 colour shades, 5 dimming levels, maintenance free
MOUNTING	rail, desk, mobile, ceiling, wall

PART No MOUNTING TYPE

CLED20LXB	Back-plate mounted examination light
CLED20L1C	Ceiling mounted examination light
CLED20LXD	Desk mounted examination light
CLED20LXM	Mobile Unit
CLED20LXR	Rail mounted examination light
CLED20LXW	Wall mounted examination light

Light Distribution

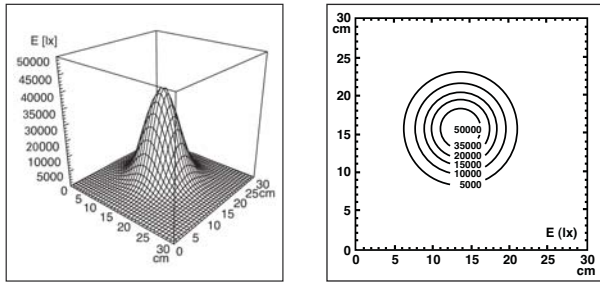

Mobile Unit

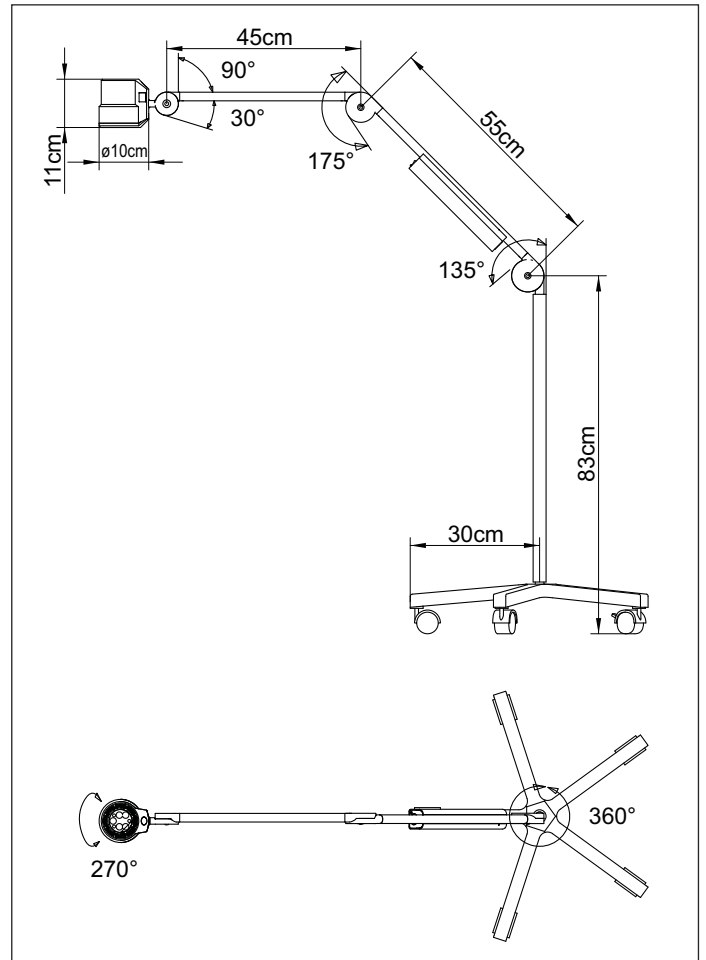

Wall Mounted

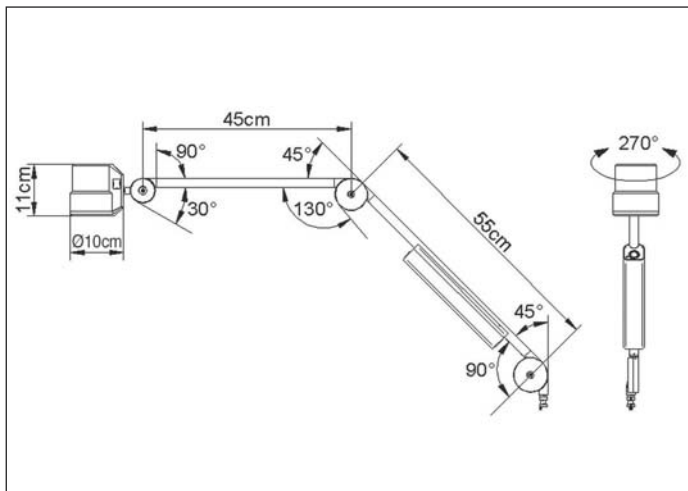
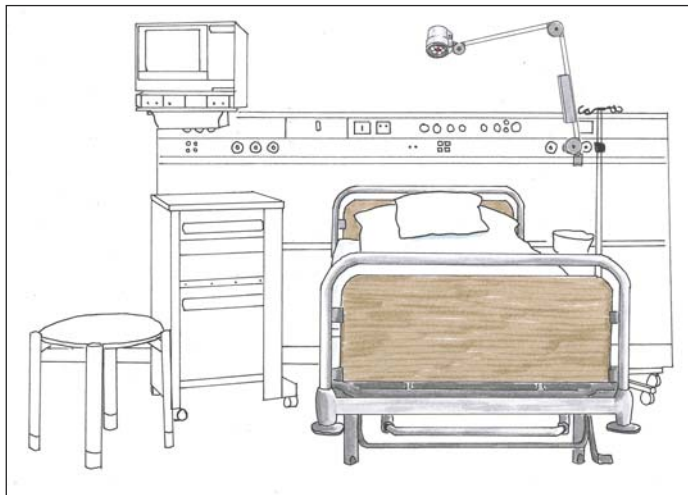

Ceiling Mounted

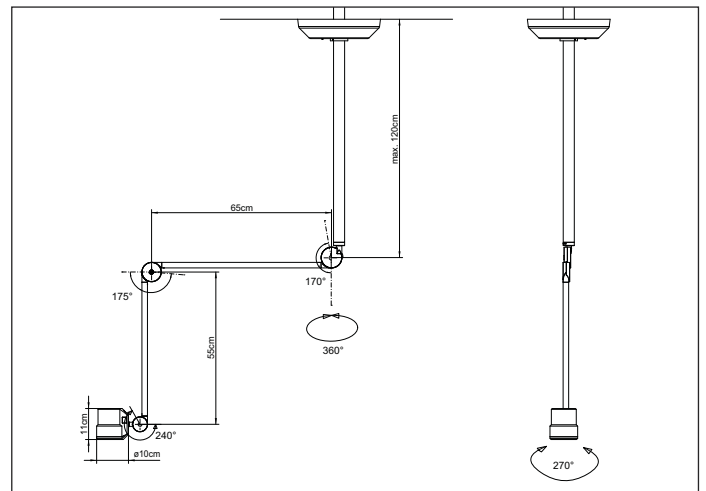

HD LED



Brandon Medical, Holme Well Road, Leeds LS10 4TQ
Tel: +44 (0)113 2777 393 Fax: +44 (0)113 2728 844 Email: enquiries@brandon-medical.com
www.brandon-medical.com

In line with the Brandon policy of progressive improvement, the right is reserved to alter specifications and/or prices without notice.
Polygiene is a registered trademark of Perstorp AB.

Brandon Medical, Quasar HD-LED, Symposia, Atlas Pendants and HD-LED are registered trademarks of Brandon Medical Co Ltd.